

Hup C 40-30

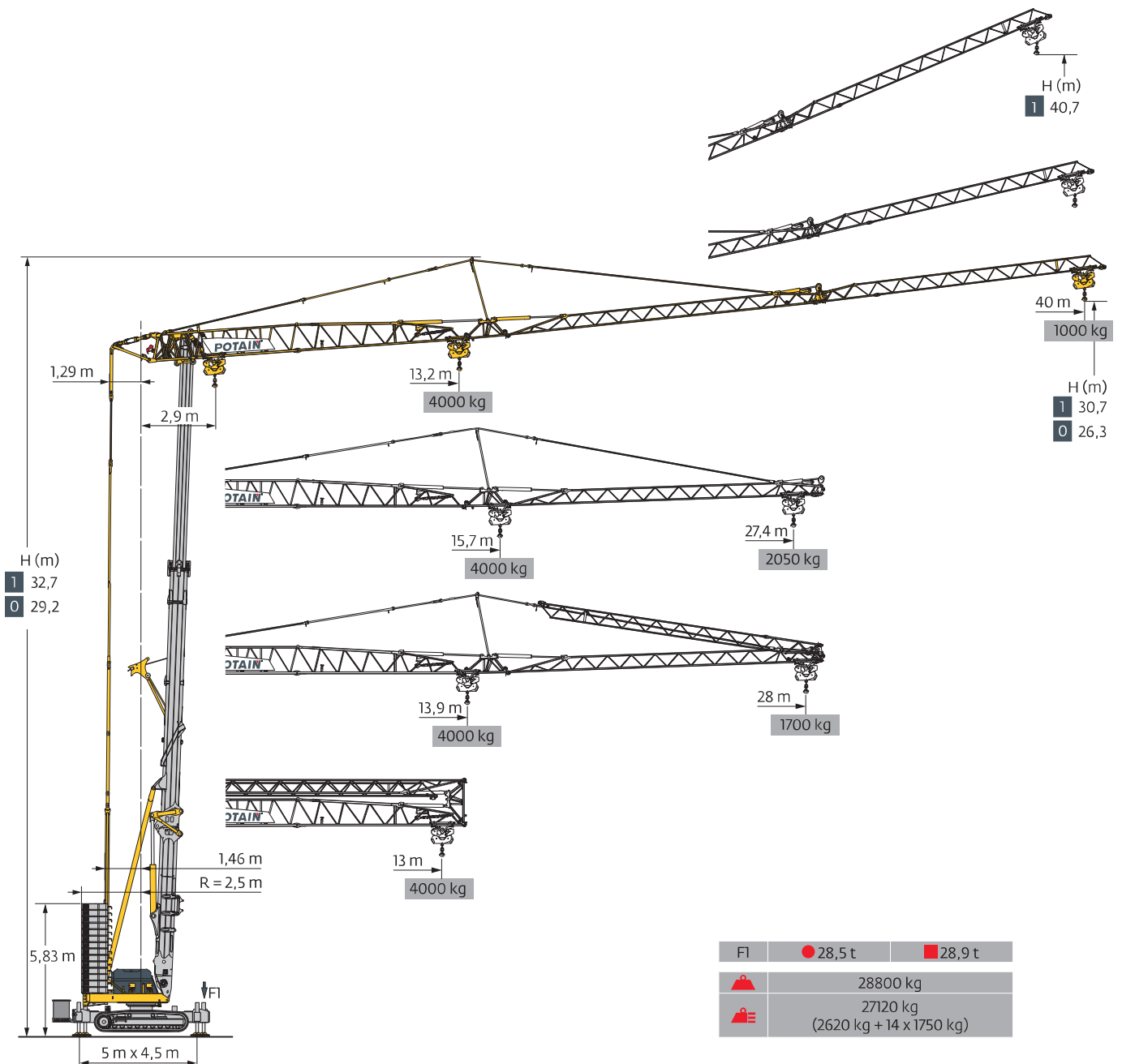

Smart Set-up Drive Control Power Control Top Site Top Tracing 3

Courbes de charges / Lastkurven / Load curves / Curvas de cargas / Curve di carico
 Curvas de carga / Кривые нагрузок

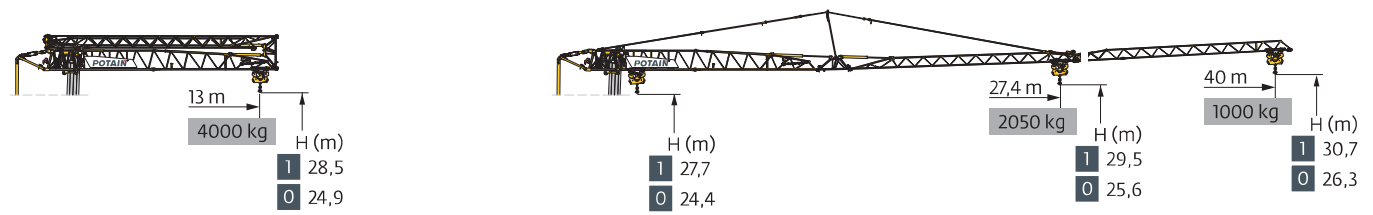

40 m	2,9	▶	13	m	2,9	▶	13,2	14	15	16	17	18	19	20	22	25	27	30	32	35	37	40	m
▲▲▲	▲						4000	3700	3400	3150	2950	2750	2550	2400	2150	1800	1650	1450	1350	1200	1100	1000	kg
27,4 m	2,9	▶	13	m	2,9	▶		15,7	16	17	18	19	20	22	25	27,4	m						
▲▲▲	▲							4000	3900	3650	3400	3200	3000	2650	2300	2050	kg						

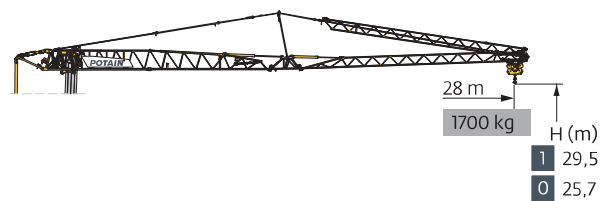



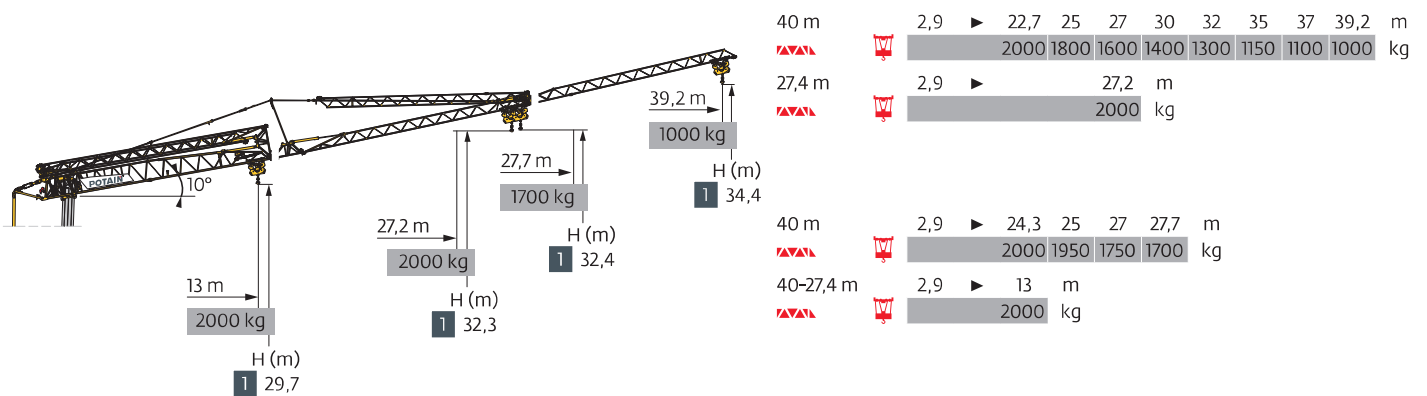

40 m	2,9	▶	13,9	14	15	16	17	18	19	20	22	25	27	28	m
▲▲▲	▲		4000	3950	3650	3350	3150	2900	2750	2550	2300	1950	1800	1700	kg

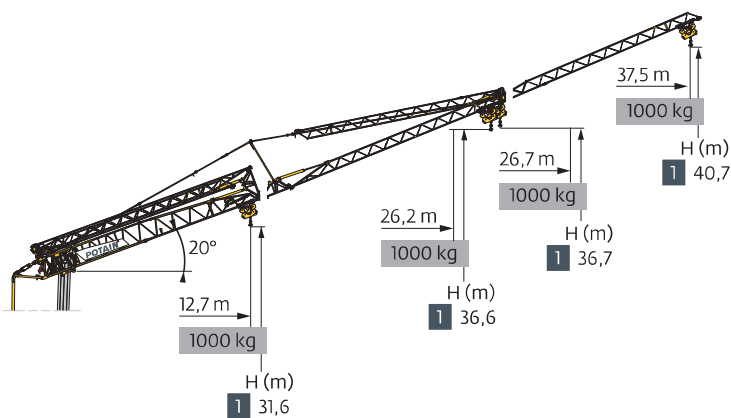





40 m	2,9	▶	22,7	25	27	30	32	35	37	39,2	m
▲▲▲	▲		2000	1800	1600	1400	1300	1150	1100	1000	kg
27,4 m	2,9	▶			27,2	m					
▲▲▲	▲				2000	kg					
40 m	2,9	▶	24,3	25	27	27,7	m				
▲▲▲	▲		2000	1950	1750	1700	kg				
40-27,4 m	2,9	▶	13	m							
▲▲▲	▲		2000	kg							



Mécanismes / Triebwerke / Mechanisms / Mecanismos / Meccanismi
 Mecanismos / Механизмы

400 V - 50 Hz 480 V - 60 Hz							ch-PS hp	kW
 18 HPL™ 10	m/min	1,7	19	36	58	65	18	13
	kg	4000	4000	2000	1000	500		
 3 DVF 5	m/min	1 → 45 (0 → 1000 kg) 1 → 41 (1000 → 4000 kg)					3	2,2
 HPS 142	tr/min U/min rpm	0 → 0,9					2 x 5	2 x 3,7

 IEC 60204-32		
400 V (+10% -10%) 50 Hz 480 V (+6% -10%) 60 Hz	23 → 17 kVA	

Montage / Montage / Erection / Montaje / Montaggio
 Montagem / Монтаж

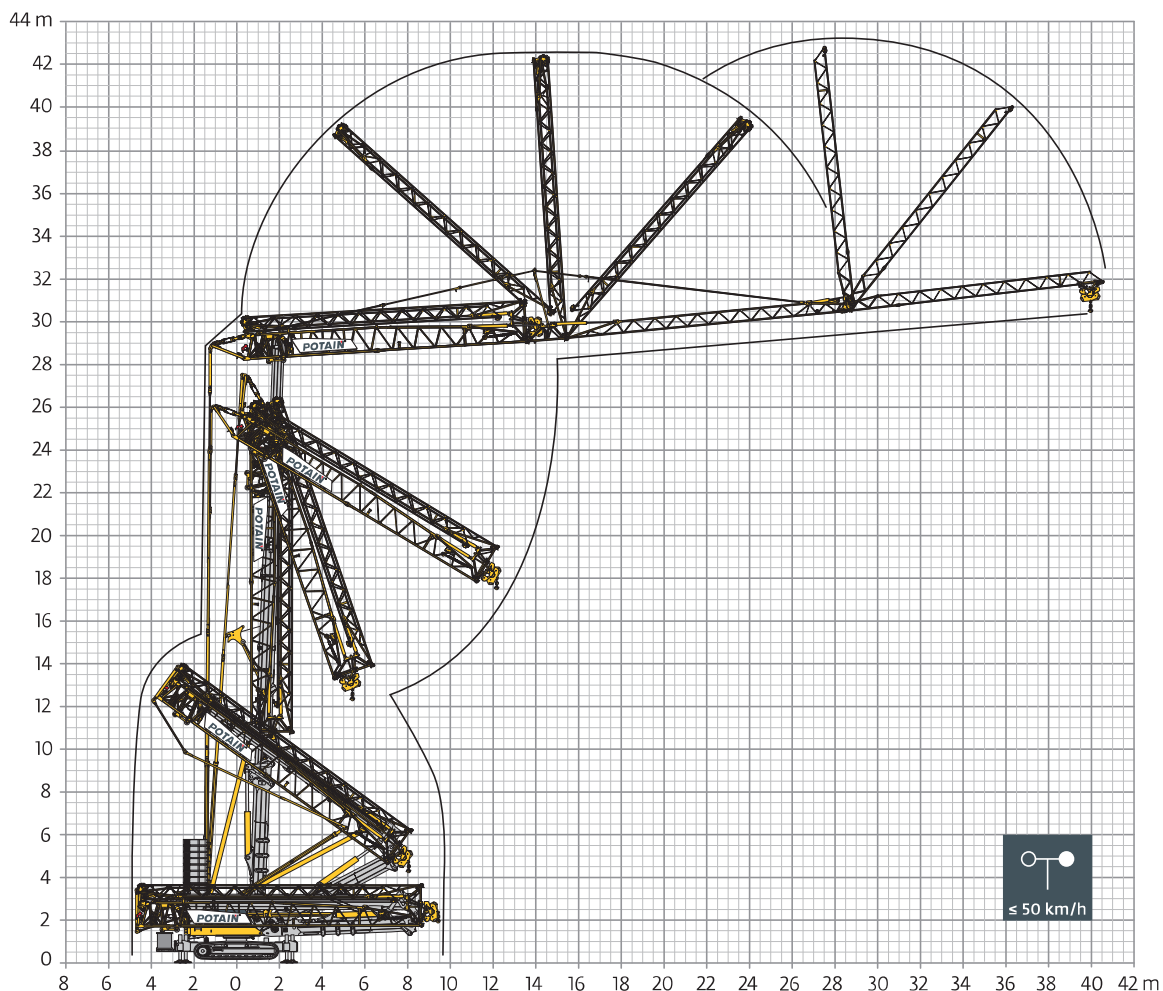

En mouvement / In Bewegung / Moving / En movimiento / In movimento
Em movimento / в движении

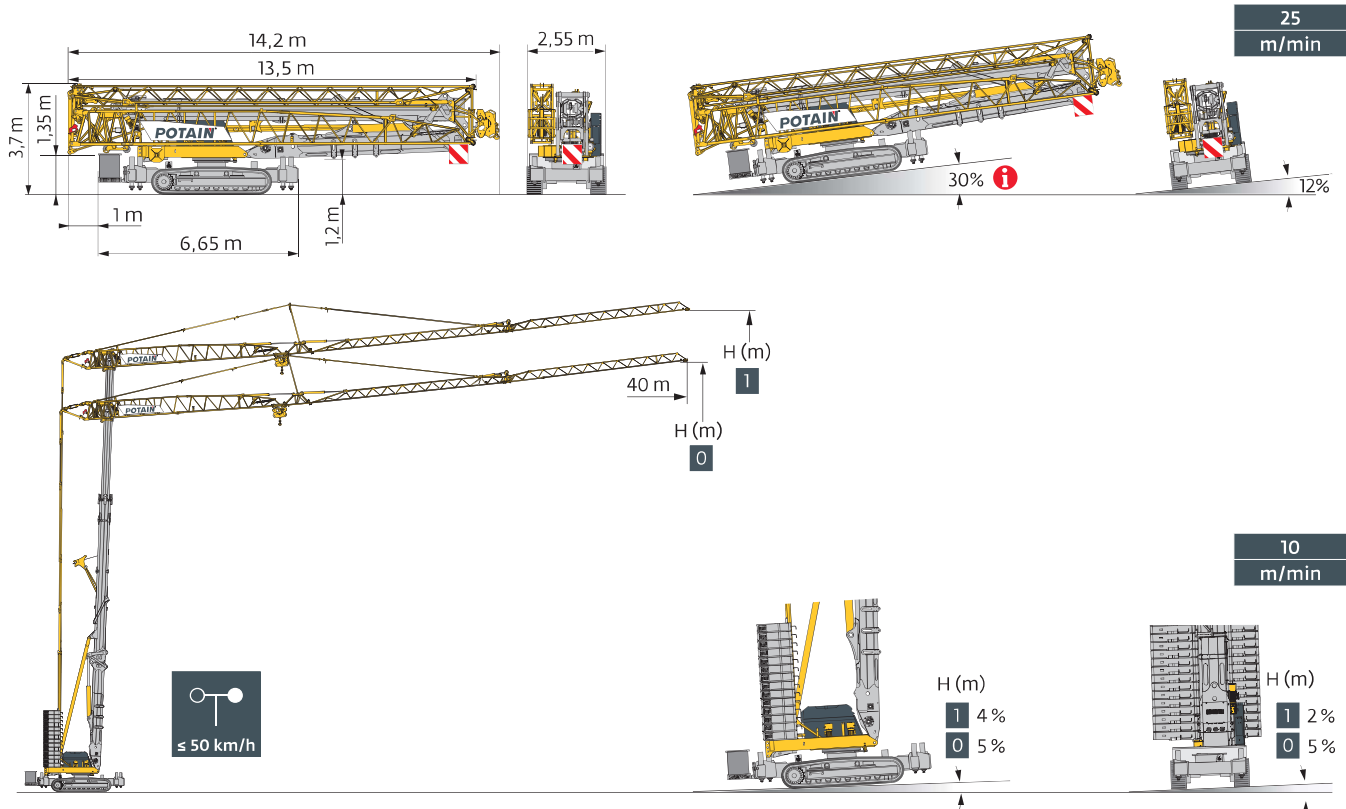

	FR	DE	EN	ES	IT	PT	RU
R	Rayon de giration	Schwenk radius	Rear slewing radius	Radio de giro	Raggio di rotazione	Raio de rotação	Задний габарит
●	Réactions en service	Reaktionskräfte in Betrieb	Reactions in service	Reacciones en servicio	Reazioni in servizio	Reacções em serviço	Реакция при работе
■	Réactions hors service	Reaktionskräfte außer Betrieb	Reactions out of service	Reacciones fuera de servicio	Reazioni fuori servizio	Reacções fora de serviço	Реакция в покое
⚖	Poids à vide, sans lest, sans trains de transport, avec flèche maxi, et hauteur standard.	Gewicht ohne Last, ohne Ballast, ohne Transportachsen, mit max. Auslager und Standardhöhe	Weight without load, without ballast, without transport axes, with max. jib and standard height	Peso en vacío, sin lastre, sin trenes de transporte con flecha y altura estándar	Peso a vuoto, senza zavorra, senza assali di trasporto, con braccio max e altezza standard.	Peso em vazio, sem lastro, sem eixos de transporte com lança máxima e altura standard.	Вес без груза, без балласта, без осей для транспортировки, с максимальным вылетом стрелы и стандартной высотой
⚖	Poids total du lest	Ballast-Gesamtgewicht	Total ballast weight	Peso total del lastre	Peso totale della zavorra	Peso total do lastro	Общий вес балласта
📦	Équipements standards	Standardausrüstungen	Standard equipment	Equipamiento de serie	Equipaggiamento standard	Equipamento de série	Стандартное оборудование
📦	Équipements optionnels	Sonderausrüstungen	Options	Equipamiento opcional	Equipaggiamento in opzione	Equipamento opcional	Дополнительное оборудование (опция)
⬆	Levage	Heben	Hoisting	Elevación	Sollevamento	Elevação	Подъем
📍	Distribution	Katzfahren	Trolleying	Distribución	Distribuzione	Distribuição	Перемещение по стреле
🔄	Orientation	Schwenken	Slewing	Orientación	Rotazione	Rotação	Поворот
⚡	Puissance requise	Erforderliche Leistung	Required power	Potencia Necesaria	Potenza richiesta	Potência Necessária	Потребляемая мощность
🕒	Fonction Power Control : vitesses treuils adaptées à la puissance disponible	Funktion Power Control: Geschwindigkeiten der Triebwerke werden an die verfügbare Leistung angepasst	Power Control Function: winch speeds adapted to the available power	Función Power Control: marchas de los cabrestantes adaptadas a la potencia disponible	Funzione Power Control: velocità degli argani adattate alla potenza disponibile	Função Power Control: velocidades de guincho adaptadas à potência disponível	Функция контроля мощности Power Control: регулировка скорости лебедок в зависимости от доступной мощности
ⓘ	Nous consulter	Auf Anfrage	Consult us	Consultarnos	Consultateci	Consultar-nos	Проконсультируйтесь у нас
⚠	Document commercial non contractuel. Pour toute information technique se référer à la notice correspondante.	Unverbindliches Vertriebsdokument. Für technische Informationen, siehe die entsprechenden Anweisungen.	This commercial document is not legally binding. For any technical information, please refer to the corresponding instructions.	Documento comercial no contractual. Para cualquier información técnica, ver la noticia correspondiente.	Documento commerciale non vincolante, per tutte le informazioni tecniche fare riferimento al catalogo istruzioni.	Documento comercial não contractual. Para qualquer informação técnica complementar consultar as respectivas instruções.	Этот коммерческий документ не является юридически обязательным. Для получения технической информации, см. соответствующие инструкции.

